

## Heated GRAB'N GO Case MODEL GNG-2P2T



<b>Capacity</b>
Accommodates 2 x Full-Size and 2 x Half-Size Pans
<b>No water connection</b>
Hold and Display Food without the use of water (no water connection required)
<b>Condensation</b>
No condensation build-up on glass
<b>Display</b>
Euro-style Curved Glass (side panels).
<b>Wide-Beam Halogen Lighting</b>
Enhances product view and stimulates sales
<b>Tempered Mirror Sliding Glass Doors</b>
Framed and removable, making display more visible and simplifying the cleaning process
<b>Coated Shatterproof Lighting</b>
Halogens
<b>Rubber Gaskets</b>
Protects the glass edges from chipping
<b>Heavy Duty Construction</b>
Manufactured with high-gauge 304 stainless steel

**RESFAB EQUIPMENT INC.**

**Toll Free: 1-866-359-0808**

[info@resfab.com](mailto:info@resfab.com) | [resfab.com](http://resfab.com)

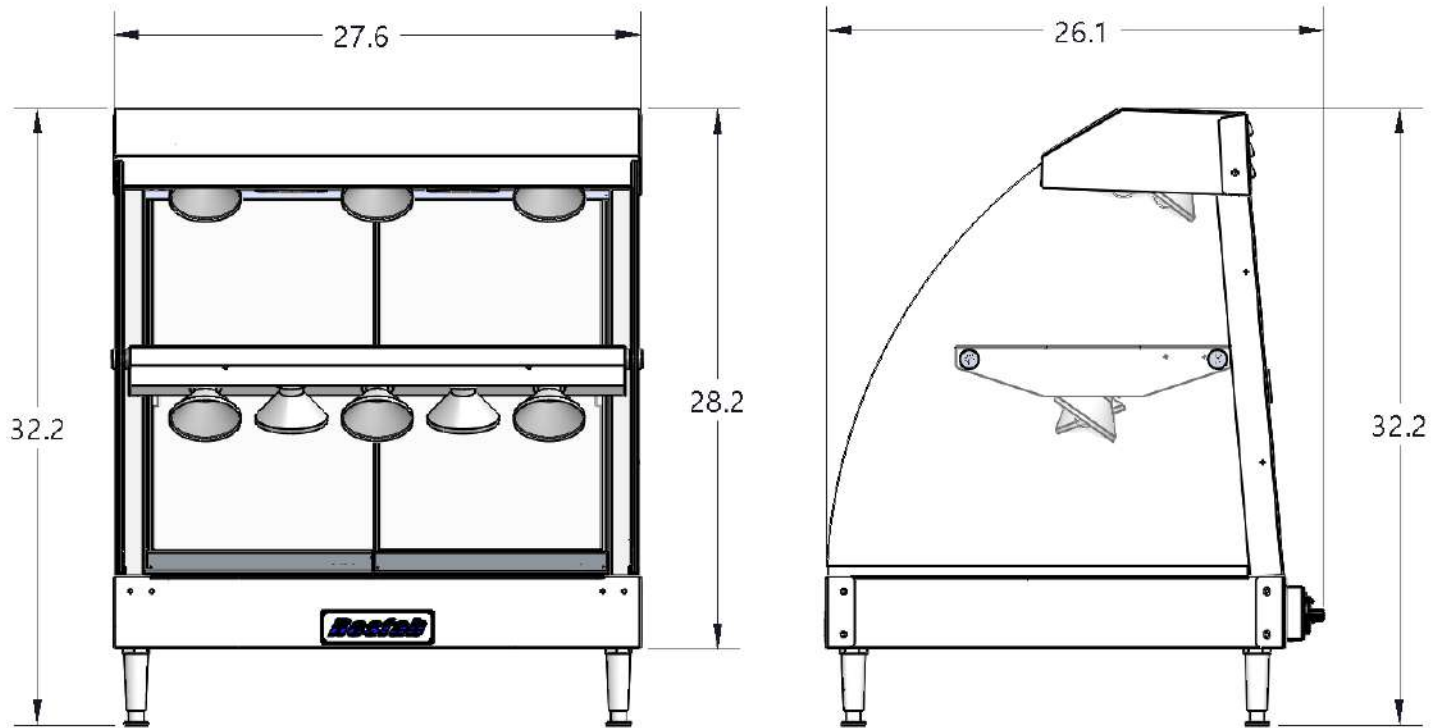

## ELECTRICAL

<b>MODEL</b>	<b>GNG-2P2T</b>
VOLTAGE	120 V
AMPERAGE	11.3 A
POWER CORD	10 ft
PLUG	NEMA 5-15P

## DIMENSIONS

WEIGHT	110 lbs
WEIGHT – CRATED	165 lbs
CRATE DIMENSIONS	W 34" x H 40" x D 30"

## INSTALLATION REQUIREMENTS

- DISPLAY CASE MUST BE INSTALLED LEVEL
- USE THE 4 LEGS OR SEAL THE CASE TO THE COUNTER WITH NSF FOOD GRADE CAULKING

**RESFAB EQUIPMENT INC.**

Toll Free: 1-866-359-0808

[info@resfab.com](mailto:info@resfab.com) | [resfab.com](http://resfab.com)