



Resfab

State-of-the-art Ventless Auto Lift Open Frying Technology



Models: MB-50AT & MB-50ATV

- **Multi-Basket Configurations:** The Auto-Lift Systems allows for the use of one large basket or two independently operating half-size baskets.
- **Idle Mode Saves Energy:** Between loads and or busy periods, an idle mode allows the operator to be in a “stand-by” position leading to significant savings in energy consumption.
- **Sleep mode:** After 30 minutes of non-use the fryer will automatically go to sleep mode. This will be additional savings in energy consumption. Recovery within seconds.
- **Zero recovery Time**
The operator can fry batch after batch without waiting for the fryer temperature to recover.
- **No Manipulation of Hot Parts**
The filtration tank slides into the fryer and automatically connects to the pump pipe, and the pump reset is accessible since there are no panels to remove. **The risk of injury is greatly reduced.**
- **Easy and Safe Transportation & Removal of Shortening/Oil**
A removable carrying handle attaches to the filtration tank (which comes equipped with casters). **OM-80 Oil Caddy available for complete Oil Management System.**
- **Safety Comes First**
Lift up heater for easier cleaning
- **No filter over-ride without PIN**



Two half Baskets

One full size basket



Touch Screen Controller features:

- **User Friendly:**
Each screen is easy to navigate and operator friendly, simplifying training and daily operation.
- **40 Programmable Menus:**
Including product name, cooking time, temperature, preset alarm to “add product”, “stir”, “alarm” and more.
- **2 Idle Pre-set Temperature Point for Energy Saving:**
Between loads and or busy periods, the idle modes allow the operator to be in a “stand-by” position leading to significant savings in energy consumption.
- **Oil Filtering Lock-out:**
The filtering lock-out allows the manager to pre-set the filtering frequency, for a better quality product and oil increased saving.
- **P.I.N. for the Controller Access:**
The Personal Identification Number controls the direct access to the main program such as “Menu”, “Filtering lock-out”, “Idle set points” and more.
- **Warnings** informs the operator of the state of the drain and discharge / rinse mode.

Ventless Hood System:

Integrated Fire Suppression System: The ventless fryer comes equipped with an integrated (Ansul R-102) fire suppression system. The unit is ready for the final charging and testing to be performed on site by an authorized Ansul distributor.

Integrated Alarm System. Unit has self contained alarm system with interlock ready to connect to the store alarm if required by your local fire code.

Ventless Hood System exceeds EPA Standard 202 for the release of particulate matters and NFPA 96

Indicator Light: An indicator light will go on to provide advanced warning that the filter needs to be replaced.

Air-Flow Sensor: A built-in sensor will automatically shut off the fryer if the HEPA filter is not replaced when required.

Guaranteed Performance: If the filters are not installed or secured properly, an “interlock” system will not allow the fryer to function.

MB-50AT

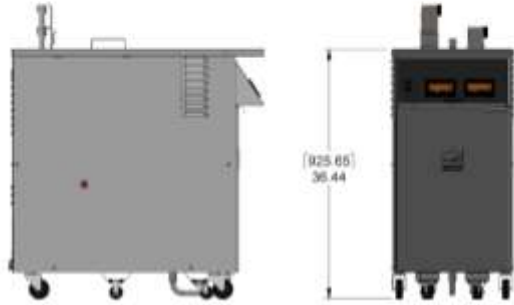
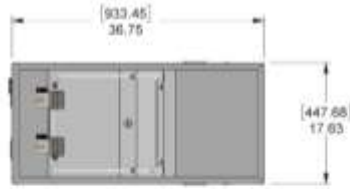

MB-50ATV

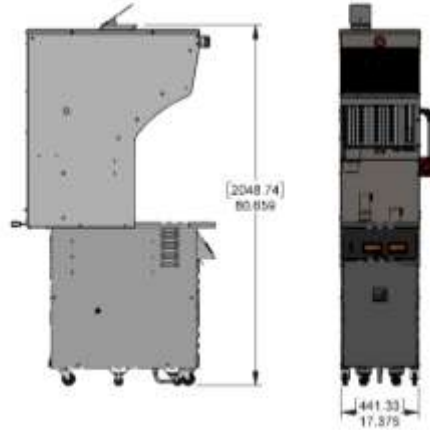
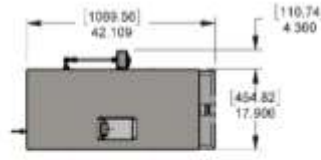

Electrical MB-50AT Crated Weight : 292 lbs.

Voltage	208		240	
Heater KW	14.4		14.4	
Phase	1	3	1	3
AMP	74	45	65	38

Electrical MB-50ATV Crated Weight : 550 lbs.

Voltage	208		240	
Heater KW	14.4		14.4	
Phase	1	3	1	3
AMP	78	48	69	41

Dimensions:

MB-50AT

MB-50ATV

Width (in)	17.2	17.2
Depth (in)	32	38.6
Height (in)	36.7	80.9
Crated Weight (lbs)	292 lbs	550 LBS

Capacity

Shortening	55 lb
Chicken Fresh Breaded*	40 pcs

* Based on 3 lb chicken, 8pc. cut

Continuing product improvement may subject specifications to change without notice



Resfab Equipment Inc.

735 Rossiter, St-Jean-sur-Richelieu, (Montréal), Québec, Canada, J3B 8A4
 Tél.: (450)-359-0800, Fax: (450)-359-0296, Toll Free: 1-866-359-0808
 E-mail: info@resfab.com, WWW.RESFAB.COM

